

S800

Specifications

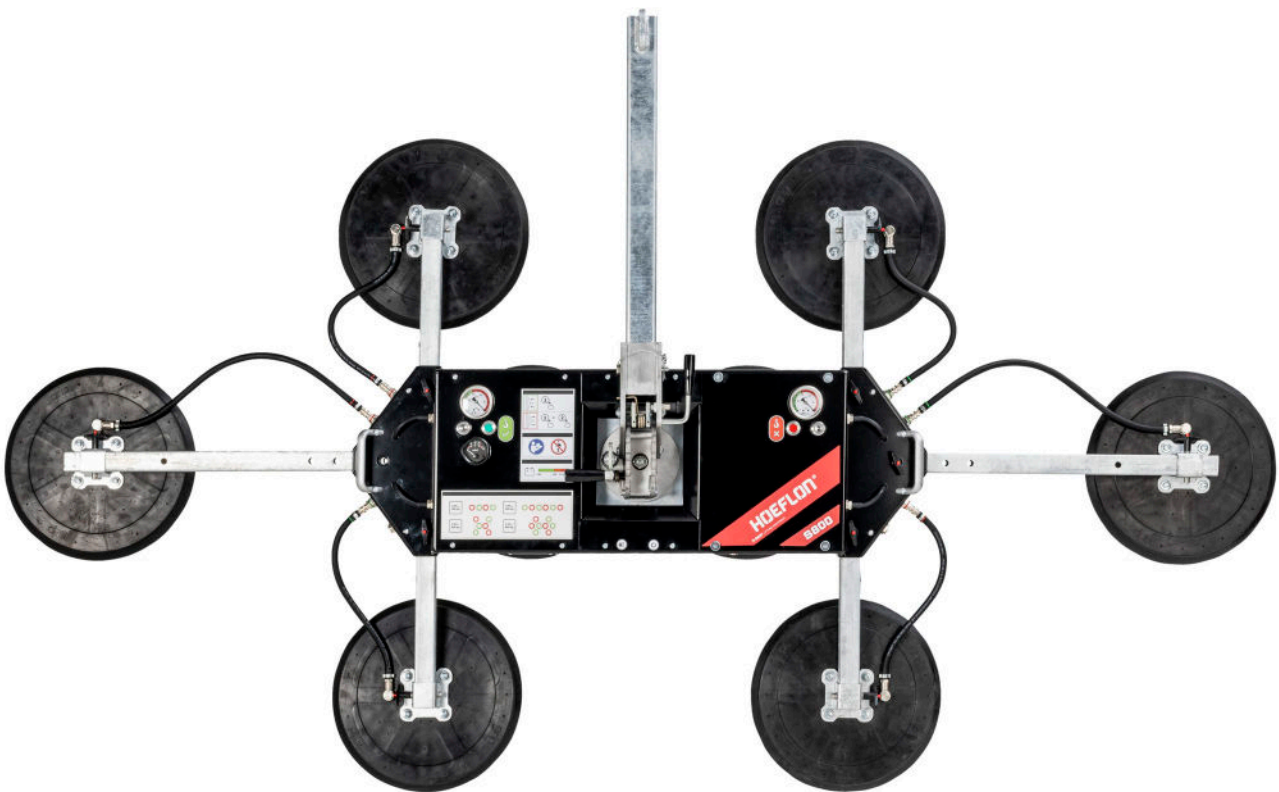

Lifting capacity Dual Circuit:	400 / 600 / 800 kg
Machine weight:	64 / 73 / 82 kg
Rotation range:	360° with four locking positions
Tilting range:	90° with six locking positions
Machine height:	190 mm
Battery:	12VDC, 10Ah

S800

Specifications

The Hoeflon S800 suction lifter is a premium quality multifunctional glass lifter, with exceptional fit and finish, at a very competitive price.

All our products are designed in-house in close cooperation with users from the field. This results in products that are a class apart when it comes to the details and provide the user with every convenience in daily use.

Unique features

- Can be used as both spider and inline suction lifter.
- At just 82 kg with a lifting capacity of 800 kg, it is the lightest suction lifter in its class.

Delivered standard with:

- Radio remote control
- Transport trolley
- Shortened lifting arm
- Legs
- Quick-change battery
- Protective covers for suction cups

Accessories



Battery



Battery charger



Remote control



Lifting arm

Specifications

- ▶ Extra-short lifting arm provides very compact dimensions for when glass installation space is limited.
- ▶ Angle adjustment on the Hoeflon lifting arm provides extra safety and convenience for indoor glazing installation because the angle can be fixed in different positions.
- ▶ Double vacuum circuit, meeting the requirements of the EN 13155 directive, ensures maximum safety and installation speed because external load fall arrester is no longer necessary.
- ▶ Radio remote control provides extra installation speed and convenience.
- ▶ The overall width of the machine is very low, which means that work can also be carried out between the façade and scaffolding.



S800

Specifications

SWL 800 kg - Spider suction lifter (82 kg)

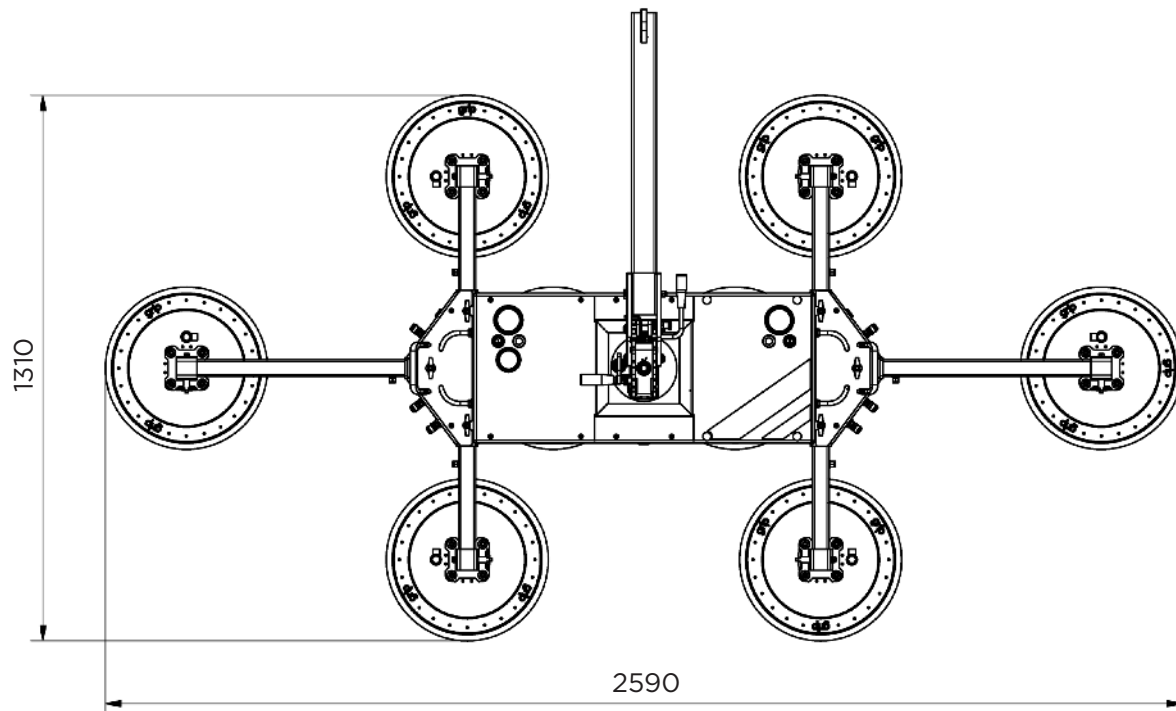

SWL 600 kg - Inline suction lifter (73 kg)

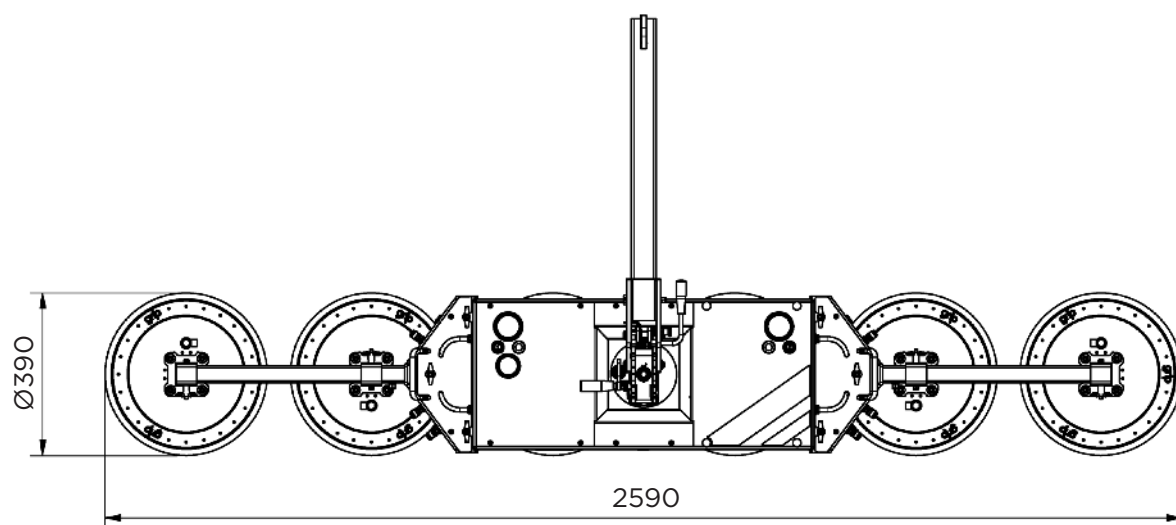

SWL 400 kg - Inline suction lifter (64 kg)

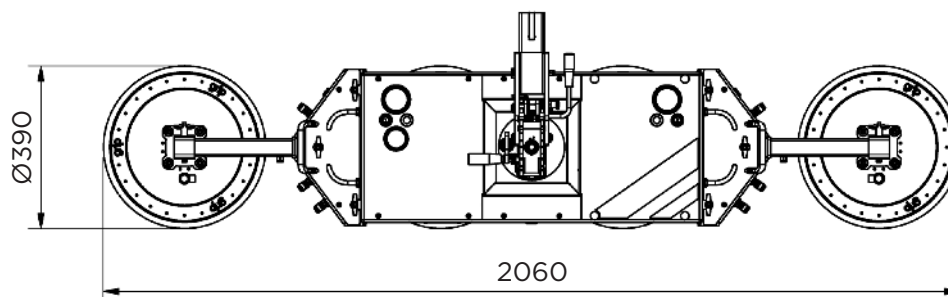

SWL 200 kg - Base unit (51 kg)

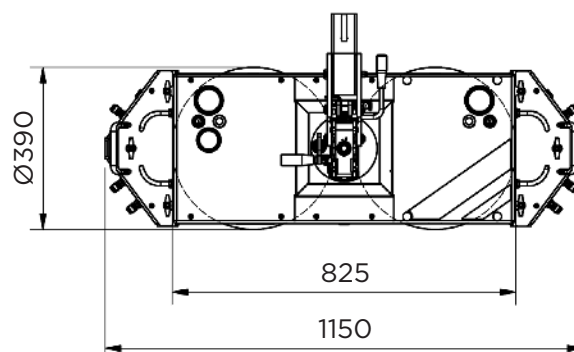

S800

Specifications

HOEFLON®

Your Hoeflon contact person

Hoeflon machines are functional and offer optimal power and reliability. We offer many possibilities and help you come up with solutions.



www.gantic.no
55 31 55 31
post@gantic.no

Bleivassvegen 34
5347 Ågotnes
Norway